

Accugate 250 Technical Specifications

Accugate 250 User Guide

All specifications are subject to change without notification.

Accugate 250 Hot Runner Bushings

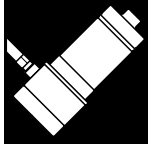

The Accugate 250 Hot Runner system is an exclusive large shot-size system with the ability to process engineering and glass-filled resins. Acceptable for crystalline and amorphous materials, this system utilizes gate diameter, gate area cooling and temperature control at the tip to optimize the part quality.

The gate can be sunk into a round depression (referred to as a “recessed gate”) so that the vestige does not protrude above the part surface. The Accugate 250 is available with one head style and four gating options to suit a broad range of applications.

Gating Options for the Accugate 250



Spreader Needle Gate Insert Tips –

The Gate Insert tips can process all types of commodity and engineering grade resins while maintaining optimal performance, with a ring shaped minimal vestige on the part. Ideal for retrofitting into existing molds that may have larger gates, the tips are available in standard and wear resistant alloys. These tips are capable of processing up to 1900 grams of low viscosity resin (see engineering charts on pages 5, 9, and 13). The tips are also available in three different tip flats to suit specific application requirements. It is recommended to gate directly over the part.



Spreader Needle Collar Gate Tips –

The Collar Gate tips replace the standard Pinpoint style in large volume applications. The improved design leaves no dead spots. These tips are capable of processing up to 1900 grams of low viscosity resin (see engineering charts on pages 5, 9, and 13). The Collar Gate tips are available in standard or wear resistant alloys, and three different tip flats to suit specific application requirements.

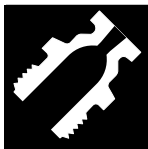

Sprue Tips –

Tips can process all types of resins, from commodity to engineering grades, while maintaining optimal performance with minimal vestige. Ideal for retrofitting into existing molds that may have larger gates. Available in standard and wear resistant alloys, these tips are capable of processing up to 4000 grams of low viscosity resin (see engineering charts on pages 5, 9, and 13).

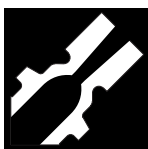

Extra Stock Sprue Tips –

Identical to the Sprue tip, except with extra stock steel at the tip that can be machined to meet customer specific requirements. Ideal for difficult access areas in the part, or for secondary runner applications. Available in standard and wear resistant alloys, these tips are capable of processing up to 4000 grams of low viscosity resin (see engineering charts on pages 5, 9, and 13).

MANIFOLD APPLICATIONS

Accugate 250 Technical Specifications

MANIFOLD APPLICATIONS

250

All specifications are subject to change without notification.

Head Options

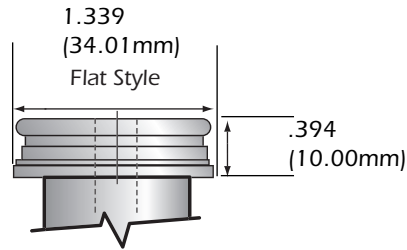

Gating Options / Bushing Dimensions

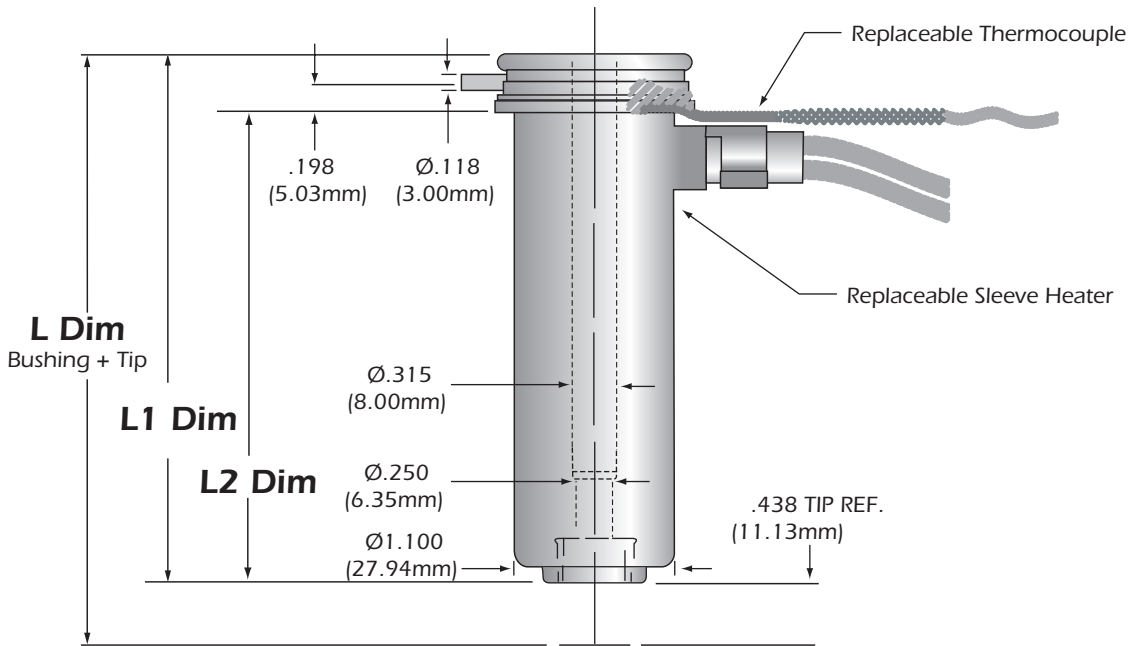

L Dim
Bushing + Tip

L Dim
Note*

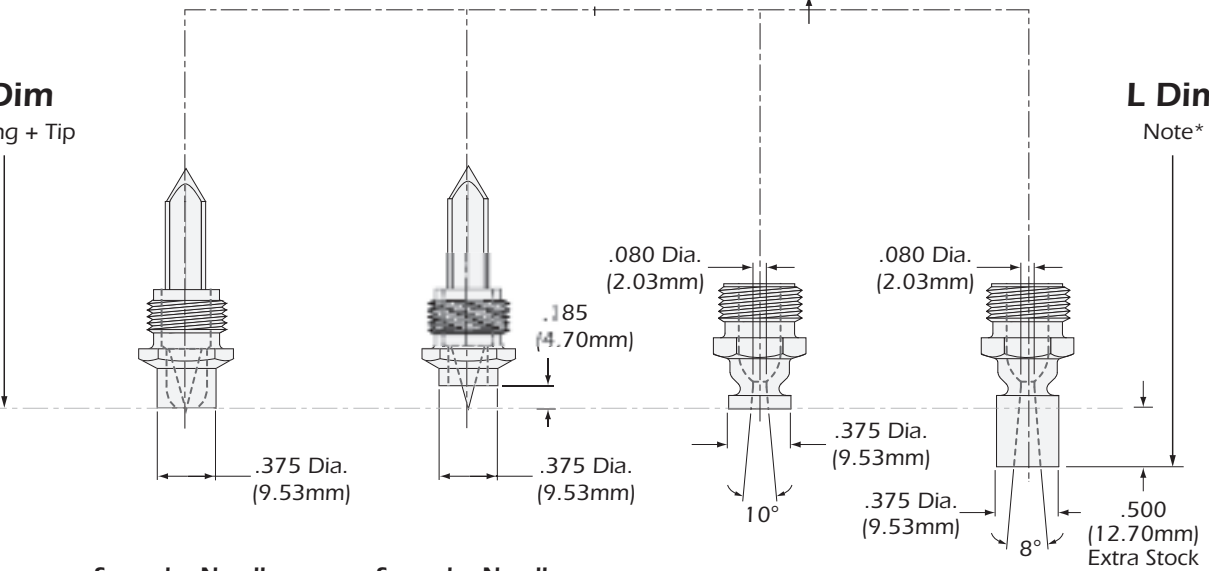

Spreader Needle Gate Insert

Spreader Needle Collar Gate

Sprue

Extra Stock Sprue

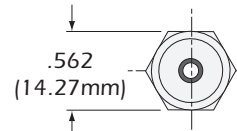
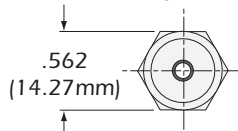
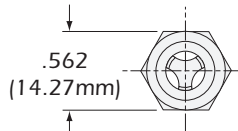
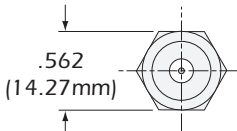

2

Dimensions are in inches. Millimeters are in parentheses.

*Note: Dimensions include extra stock.
**Note: For additional gate dimensions see page 4.

Accugate 250 Technical Specifications

MANIFOLD APPLICATIONS

250 Ordering Charts

Chart A

Flat

Part Number	L Dim. Gl, CG, Sprue		L Dim. Extra Stock Sprue		Flat Body Heater		L1 Dim.		L2 Dim.		T/C	Watts
HWA2502	2.563	(65.10)	3.063	(77.80)	AB25002	RH25000	2.125	(53.98)	1.731	(43.97)	TC00011	295
HWA2505	3.063	(77.80)	3.563	(90.50)	AB25005	RH25001	2.625	(66.68)	2.231	(56.67)	TC00012	350
HWA2508	3.563	(90.50)	4.063	(103.20)	AB25008	RH25002	3.125	(79.38)	2.731	(69.37)	TC00013	350
HWA2511	4.063	(103.20)	4.563	(115.90)	AB25011	RH25003	3.625	(92.08)	3.231	(82.07)	TC00014	400
HWA2514	4.563	(115.90)	5.063	(128.60)	AB25014	RH25004	4.125	(104.78)	3.731	(94.77)	TC00015	400
HWA2517	5.063	(128.60)	5.563	(141.30)	AB25017	RH25005	4.625	(117.48)	4.231	(107.47)	TC00016	460
HWA2520	6.063	(154.00)	6.563	(166.70)	AB25020	RH25006	5.625	(142.88)	5.231	(132.87)	TC00017	470
HWA2523	7.063	(179.40)	7.563	(192.10)	AB25023	RH25007	6.625	(168.28)	6.231	(158.27)	TC00018	560
HWA2526	8.063	(204.80)	8.563	(217.50)	AB25026	RH25008	7.625	(193.68)	7.231	(183.67)	TC00019	650
HWA2529	9.063	(230.20)	9.563	(242.90)	AB25029	RH25009	8.625	(219.08)	8.231	(209.07)	TC00020	740
HWA2532	10.063	(255.60)	10.563	(268.30)	AB25031	RH25010	9.625	(244.48)	9.231	(234.47)	TC00021	830

Dimensions are in inches. Millimeters are in parentheses.

Tip Ordering Numbers

Chart B

Gate Style	Tip Alloy	Spreader Needle Assembly Part Numbers		
Gate Insert	Tip Alloy	0.020" Flat	0.040" Flat	0.070" Flat
	Standard	HT25030	HT25032	HT25034
	Wear Resistant	HT25031	HT25033	HT25035
Gate Style	Tip Alloy	Spreader Needle Assembly Part Numbers		
Collar Gate	Tip Alloy	0.020" Flat	0.040" Flat	0.070" Flat
	Standard	HT25040	HT25042	HT25044
	Wear Resistant	HT25041	HT25043	HT25045

Chart C

Gate Style	Tip Alloy	Part Number
	Standard	HT25010
	Wear Resistant	HT25011
Gate Style	Tip Alloy	Part Number
	Standard	HT25020
	Wear Resistant	HT25021

All specifications are subject to change without notification.

Accugate 250 Technical Specifications

MANIFOLD APPLICATIONS

250 Bore & Gate Dimensions

All specifications are subject to change without notification.

Tol. "a" Chart

in:	+ 0.001
	- 0
mm:	+ 0.03
	- 0

Tol. "b" Chart

in:	+ 0.0003m
	- 0.0003m
mm:	+ 0.0008m
	- 0.0008m

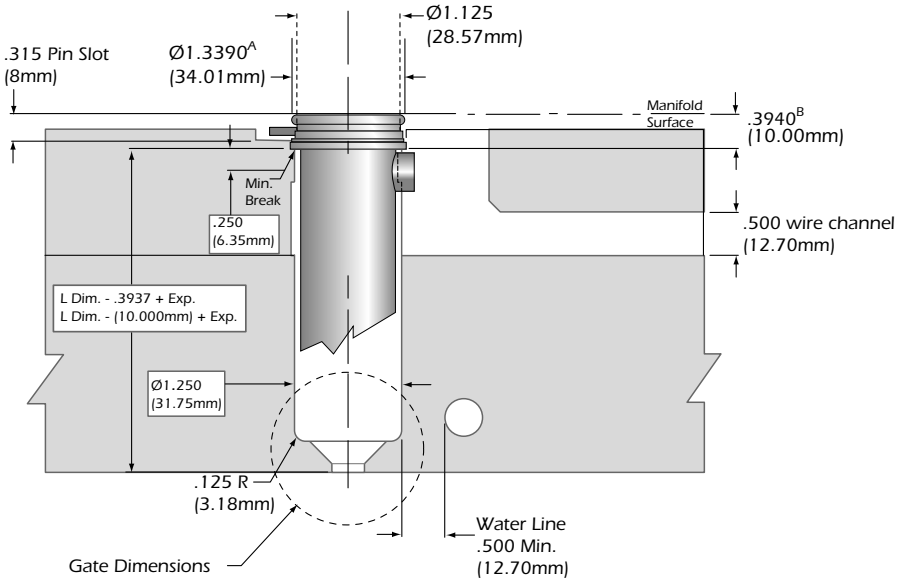

Thermal Expansion (Exp.) Formulas

$$\text{Exp. in} = (L \text{ in.} - .3940) \times 7.5 \times 10^{-6} \times (\text{Processing Temp.} - 70^\circ\text{F})$$

$$\text{Exp. mm} = (L \text{ mm.} - 10.00) \times 12.4 \times 10^{-6} \times (\text{Processing Temp.} - 21^\circ\text{C})$$

$$\text{Ref: } 10^{-6} = 0.000001$$

Dimensions are in inches. Millimeters are in parentheses.

Collar Gate

Non-Recessed Gate*

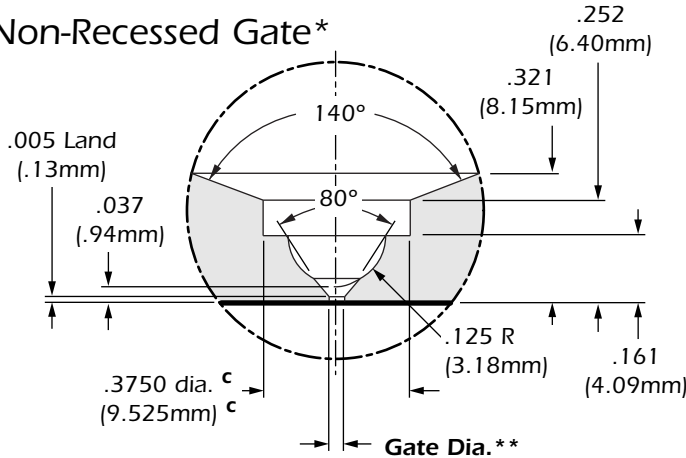

Recessed Gate*

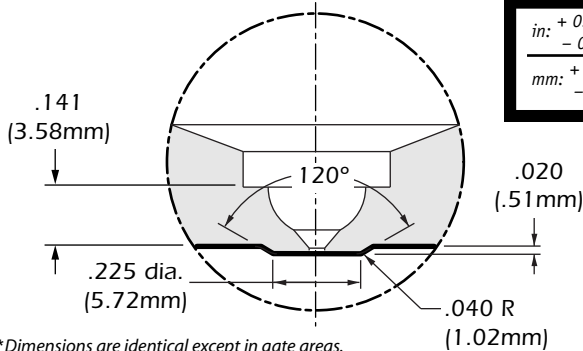

Tol. "c" Chart

in:	+ 0.0005
	- 0
mm:	+ 0.01
	- 0

*Dimensions are identical except in gate areas.
**See Chart 2, page 5 for gate diameters.

Gate Insert & Sprue Gate

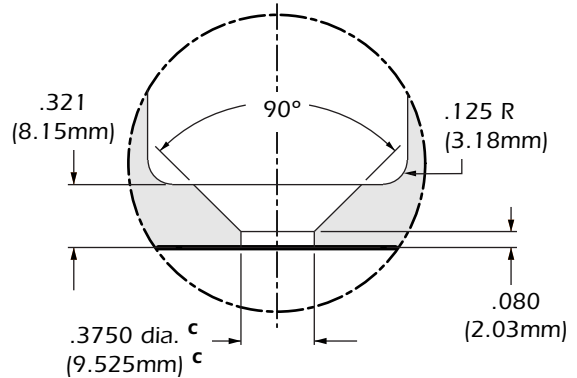

Extra Stock Sprue Gate

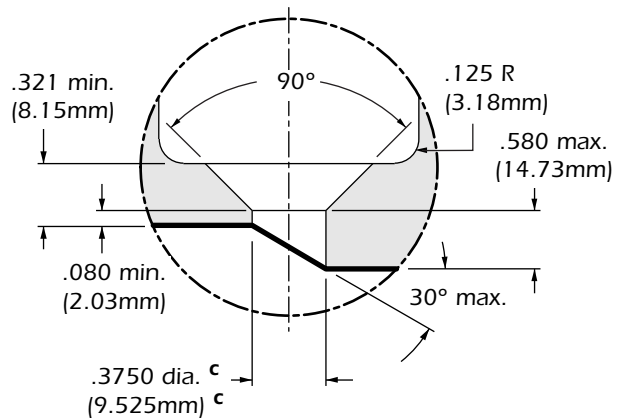

4

Accugate 250 Technical Specifications

250 Engineering Charts

Chart 1

Tip Alloy Reference: STD = Standard, WR = Wear Resistant

All specifications are subject to change without notification.

Tip Style	Part No.	Alloy	Commodity Resin	Engineering Resin	Glass-Filled Resin
Sprue	HT25010	STD	●	●	
	HT25011	WR	●	●	●
Extra Stock Sprue	HT25020	STD	●	●	
	HT25021	WR	●	●	●
Gate Insert 0.020" Flat	HT25030	STD	●	●	
	HT25031	WR	●	●	●
Gate Insert 0.040" Flat	HT25032	STD	●	●	
	HT25033	WR	●	●	●
Gate Insert 0.070" Flat	HT25034	STD	●	●	
	HT25035	WR	●	●	●
Collar Gate 0.020" Flat	HT25040	STD	●	●	
	HT25041	WR	●	●	●
Collar Gate 0.040" Flat	HT25042	STD	●	●	
	HT25043	WR	●	●	●
Collar Gate 0.070" Flat	HT25044	STD	●	●	
	HT25045	WR	●	●	●

Reference: ● = Recommended

Chart 2

Spreader Needle tips	Resin Viscosity		
	High	Medium	Low
Gate Insert 0.020" Flat	.082" to .114"	.060" to .082"	.040" to .060"
Collar Gate 0.020" Flat	(2.10mm to 2.90mm)	(1.50mm to 2.10mm)	(1.00mm to 1.50mm)
Gate Insert 0.040" Flat	.102" to .134"	.080" to .102"	.060" to .080"
Collar Gate 0.040" Flat	(2.60mm to 3.40mm)	(2.00mm to 2.60mm)	(1.50mm to 2.00mm)
Gate Insert 0.070" Flat	.132" to .164"	.110" to .132"	.090" to .110"
Collar Gate 0.070" Flat	(3.40mm to 4.20mm)	(2.80mm to 3.40mm)	(2.30mm to 2.80mm)
Sprue tips	High	Medium	Low
All Sprue	.081" to .125"*	.081" to .125"*	.081" to .125"*
Part Numbers	(2.10mm to 3.20mm)	(2.10mm to 3.20mm)	(2.10mm to 3.20mm)

Reference: High Viscosity = Melt Flow (0.02 – 6); Medium Viscosity = Melt Flow (7 – 16); Low Viscosity = Melt Flow (16 – up). The values expressed in grams are for reference purposes only. Part dimensions, wall thickness, mold condition, and molding parameters must also be considered.

*Re-machine gate diameter, if necessary, for larger shot weights.

Dimensions are in inches. Millimeters are in parentheses.

Chart 3

Resin Viscosity	Sprue Tips & Collar Gate Tip - Flats						
	Extra Stock Sprue Tips	Gate Insert Tip - Flats			Collar Gate Tip - Flats		
		0.020"	0.040"	0.070"	0.020"	0.040"	0.070"
LOW	500	90	190	350	90	190	350
MEDIUM	300	70	150	250	70	150	250
HIGH	100	50	100	150	50	100	150

Consult Heaterwerks when changing Max. shot weight.

MANIFOLD APPLICATIONS

Accugate 375 Technical Specifications

MANIFOLD APPLICATIONS

375

All specifications are subject to change without notification.

Head Options

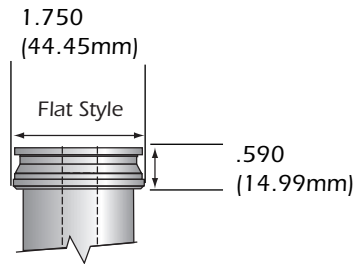

Gating Options / Bushing Dimensions

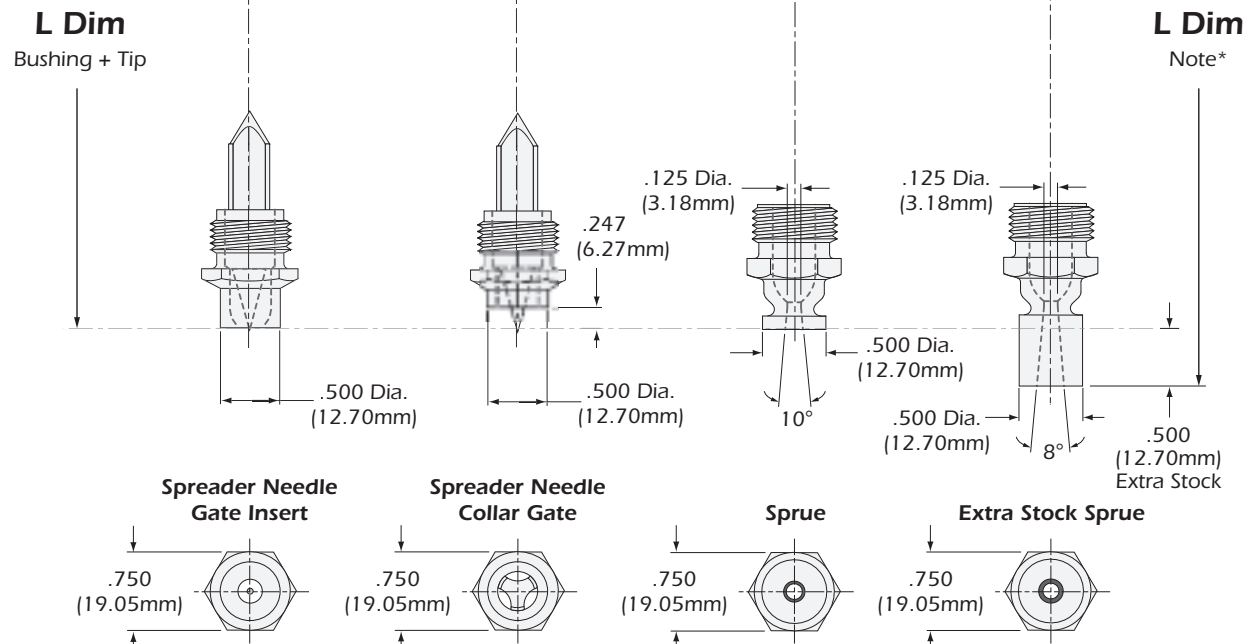
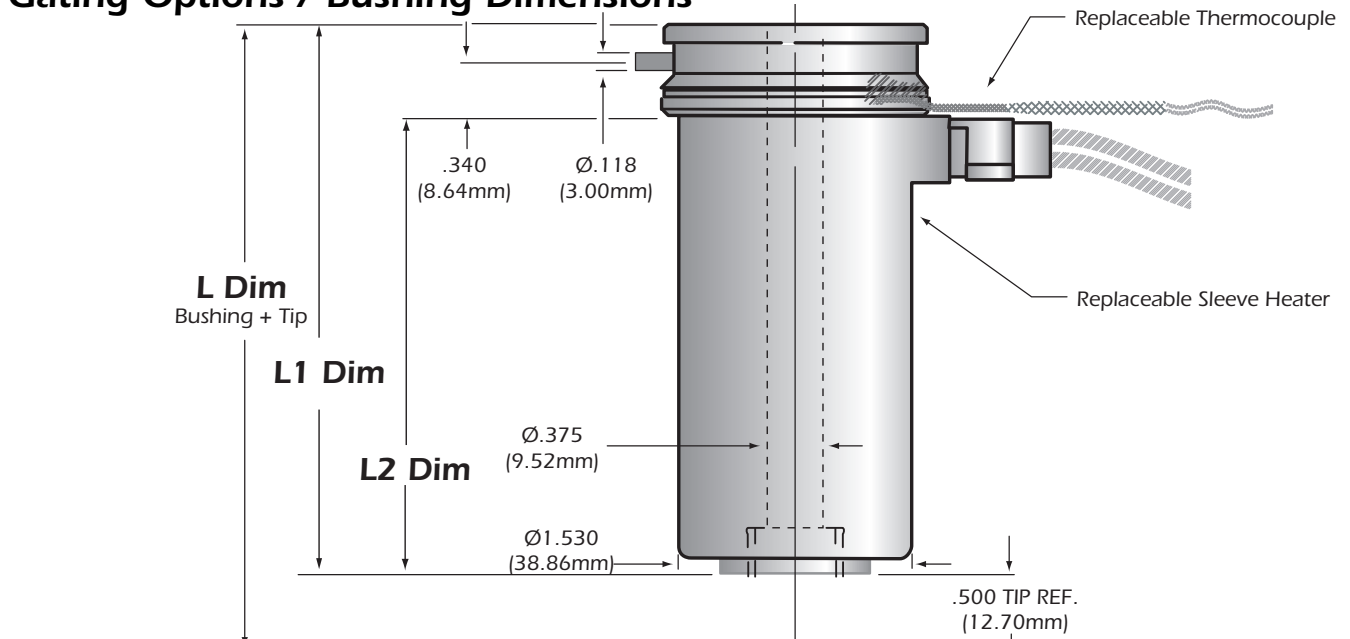

Dimensions are in inches. Millimeters are in parentheses.

*Note: Dimensions include extra stock.
**Note: For additional gate dimensions see page 8.

Accugate 375 Technical Specifications

MANIFOLD APPLICATIONS

Flat

Chart A

375 Ordering Charts

Part Number	L Dim. GI, CG, Sprue		L Dim. Extra Stock Sprue		Body	Heater	L1 Dim.		L2 Dim.		T/C	Watts
HWA3702	2.625	(66.68)	3.125	(79.38)	AB37002	RH37000	2.125	(53.98)	1.535	(38.99)	TC00022	460
HWA3705	3.125	(79.38)	3.625	(92.08)	AB37005	RH37001	2.625	(66.68)	2.035	(51.69)	TC00023	460
HWA3708	3.625	(92.08)	4.125	(104.78)	AB37008	RH37002	3.125	(79.38)	2.535	(64.39)	TC00024	610
HWA3711	4.125	(104.78)	4.625	(117.48)	AB37011	RH37003	3.625	(92.08)	3.035	(77.09)	TC00025	610
HWA3714	4.625	(117.48)	5.125	(130.18)	AB37014	RH37004	4.125	(104.78)	3.535	(89.79)	TC00026	610
HWA3717	5.125	(130.18)	5.625	(142.88)	AB37017	RH37005	4.625	(117.48)	4.035	(102.49)	TC00027	690
HWA3720	6.125	(155.58)	6.625	(168.28)	AB37020	RH37006	5.625	(142.88)	5.035	(127.89)	TC00028	690
HWA3723	7.125	(180.98)	7.625	(193.68)	AB37023	RH37007	6.625	(168.28)	6.035	(153.29)	TC00029	765
HWA3726	8.125	(206.38)	8.625	(219.08)	AB37026	RH37008	7.625	(193.68)	7.035	(178.69)	TC00030	890
HWA3729	9.125	(231.78)	9.625	(244.48)	AB37029	RH37009	8.625	(219.08)	8.035	(204.09)	TC00031	1020
HWA3732	10.125	(257.18)	10.625	(269.88)	AB37032	RH37010	9.625	(244.48)	9.035	(229.49)	TC00032	1145
HWA3735	11.125	(282.58)	11.625	(295.28)	AB37035	RH37011	10.625	(269.88)	10.035	(254.39)	TC00033	1270
HWA3738	12.125	(307.98)	12.625	(320.68)	AB37038	RH37012	11.625	(295.28)	11.035	(280.29)	TC00034	1395
HWA3741	13.125	(333.38)	13.625	(346.08)	AB37041	RH37013	12.625	(320.68)	12.035	(305.69)	TC00035	1520
HWA3744	14.125	(358.78)	14.625	(371.48)	AB37044	RH37014	13.625	(346.08)	13.035	(331.09)	TC00036	1650
HWA3747	15.125	(384.18)	15.625	(396.88)	AB37047	RH37015	14.625	(371.48)	14.035	(356.49)	TC00037	1775

Dimensions are in inches. Millimeters are in parentheses.

Chart B

Tip Ordering Numbers



Gate Style	Tip Alloy	Spreader Needle Assembly Part Numbers		
Gate Insert	Tip Alloy	0.065" Flat	0.080" Flat	0.100" Flat
	Standard	HT37030	HT37032	HT37034
	Wear Resistant	HT37031	HT37033	HT37035
Gate Style	Tip Alloy	Spreader Needle Assembly Part Numbers		
Collar Gate	Tip Alloy	0.065" Flat	0.080" Flat	0.100" Flat
	Standard	HT37040	HT37042	HT37044
	Wear Resistant	HT37041	HT37043	HT37045

Chart C

Gate Style	Tip Alloy	Part Number
	Standard	HT37010
	Wear Resistant	HT37011
Gate Style	Tip Alloy	Part Number
	Standard	HT37020
	Wear Resistant	HT37021

All specifications are subject to change without notification.

Accugate 375 Technical Specifications

MANIFOLD APPLICATIONS

375 Bore & Gate Dimensions

All specifications are subject to change without notification.

Tol. "a" Chart

in:	+ 0.001
	- 0
mm:	+ 0.03
	- 0

Tol. "b" Chart

in:	+ 0.0003m
	- 0.0003m
mm:	+ 0.0008m
	- 0.0008m

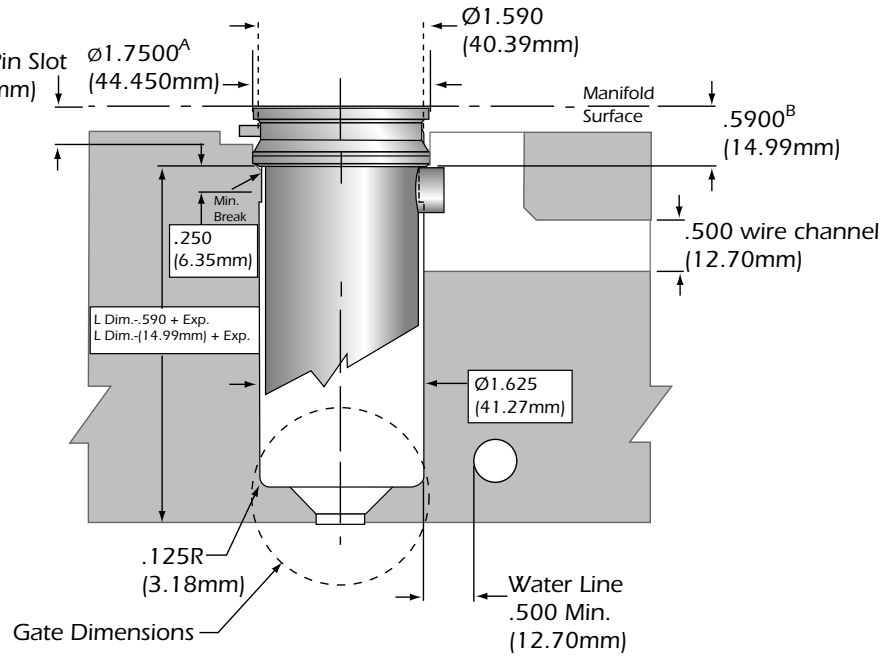

Thermal Expansion (Exp.) Formulas

$$\text{Exp. in} = (L \text{ in.} - .5900) \times 7.5 \times 10^{-6} \times (\text{Processing Temp.} - 70^\circ\text{F})$$

$$\text{Exp. mm} = (L \text{ mm.} - 14.99) \times 12.4 \times 10^{-6} \times (\text{Processing Temp.} - 21^\circ\text{C})$$

$$\text{Ref: } 10^{-6} = 0.000001$$

Dimensions are in inches. Millimeters are in parentheses.

Collar Gate

Non-Recessed Gate*

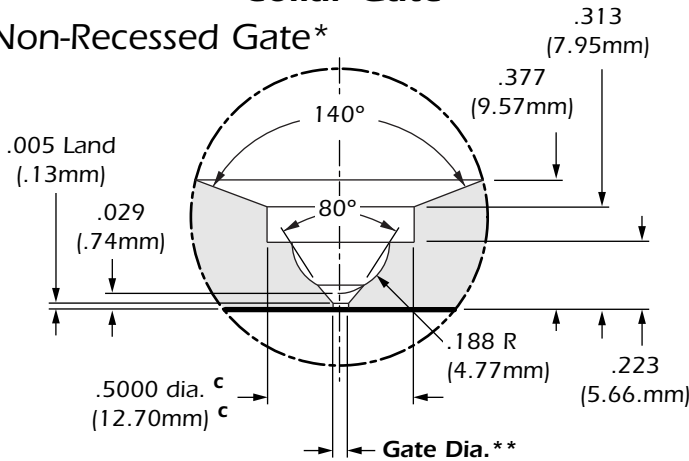

Gate Insert & Sprue Gate

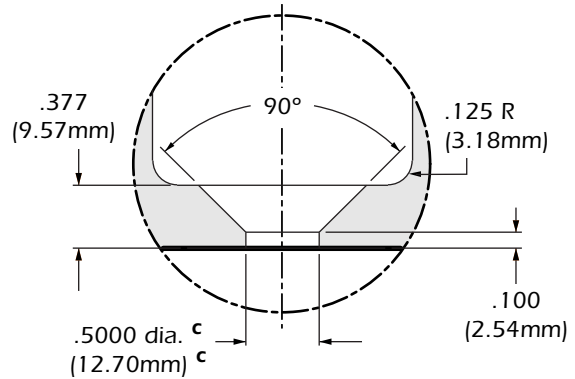

Recessed Gate*

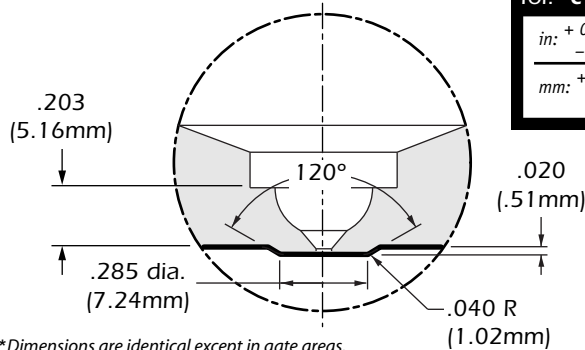

Tol. "c" Chart

in:	+ 0.0005
	- 0
mm:	+ 0.01
	- 0

Extra Stock Sprue Gate

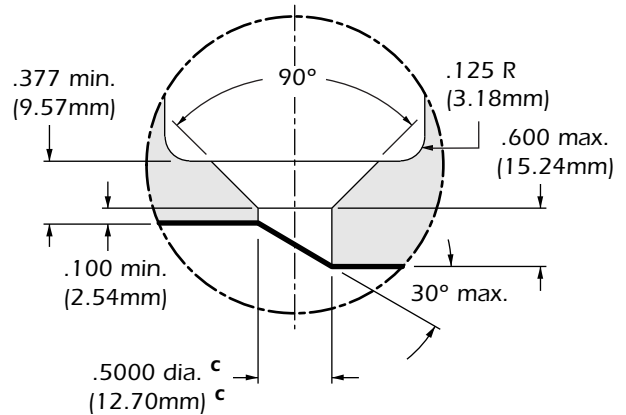

8

*Dimensions are identical except in gate areas.
**See Chart 2, page 9 for gate diameters.

Accugate 375 Technical Specifications

375 Engineering Charts

Chart 1

Tip Alloy Reference: STD = Standard, WR = Wear Resistant

All specifications are subject to change without notification.

Tip Style	Part No.	Alloy	Commodity Resin	Engineering Resin	Glass-Filled Resin
Sprue	HT37010	STD	●	●	
	HT37011	WR	●	●	●
Extra Stock Sprue	HT37020	STD	●	●	
	HT37021	WR	●	●	●
Gate Insert 0.065" Flat	HT37030	STD	●	●	
	HT37031	WR	●	●	●
Gate Insert 0.080" Flat	HT37032	STD	●	●	
	HT37033	WR	●	●	●
Gate Insert 0.100" Flat	HT37034	STD	●	●	
	HT37035	WR	●	●	●
Collar Gate 0.065" Flat	HT37040	STD	●	●	
	HT37041	WR	●	●	●
Collar Gate 0.080" Flat	HT37042	STD	●	●	
	HT37043	WR	●	●	●
Collar Gate 0.100" Flat	HT37044	STD	●	●	
	HT37045	WR	●	●	●

Reference: ● = Recommended

Chart 2

Spreader Needle tips	Resin Viscosity		
	High	Medium	Low
Gate Insert 0.065" Flat	.127" to .159"	.105" to .127"	.085" to .105"
Collar Gate 0.065" Flat	(3.20mm to 4.00mm)	(2.70mm to 3.20mm)	(2.20mm to 2.70mm)
Gate Insert 0.080" Flat	.142" to .174"	.120" to .142"	.100" to .120"
Collar Gate 0.080" Flat	(3.60mm to 4.40mm)	(3.00mm to 3.60mm)	(2.50mm to 3.00mm)
Gate Insert 0.100" Flat	.162" to .194"	.140" to .162"	.120" to .140"
Collar Gate 0.100" Flat	(4.10mm to 4.90mm)	(3.60mm to 4.10mm)	(3.00mm to 3.60mm)
Sprue tips	High	Medium	Low
All Sprue	.125" to .250"*	.125" to .250"*	.125" to .250"*
Part Numbers	(3.20mm to 6.40mm)	(3.20mm to 6.40mm)	(3.20mm to 6.40mm)

Reference: High Viscosity = Melt Flow (0.02 – 6); Medium Viscosity = Melt Flow (7 – 16); Low Viscosity = Melt Flow (16 – up).
The values expressed in grams are for reference purposes only. Part dimensions, wall thickness, mold condition, and molding parameters must also be considered.

*Re-machine gate diameter, if necessary, for larger shot weights.

Dimensions are in inches. Millimeters are in parentheses.

Chart 3

Resin Viscosity	Sprue Tips & Gate Insert Tip - Flats						
	Extra Stock Sprue Tips	Gate Insert Tip - Flats			Collar Gate Tip - Flats		
		0.065"	0.080"	0.100"	0.065"	0.080"	0.100"
LOW	2000	350	400	500	350	400	500
MEDIUM	1000	300	350	450	300	350	450
HIGH	500	250	300	400	250	300	400

Consult Heaterwerks when changing Max. shot weight.

MANIFOLD APPLICATIONS

Accugate 625 Technical Specifications

MANIFOLD APPLICATIONS

625

All specifications are subject to change without notification.

Head Options

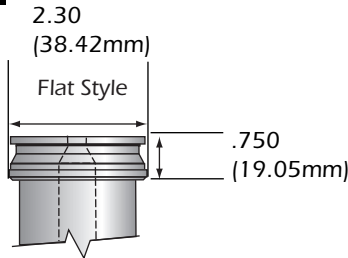

Gating Options / Bushing Dimensions

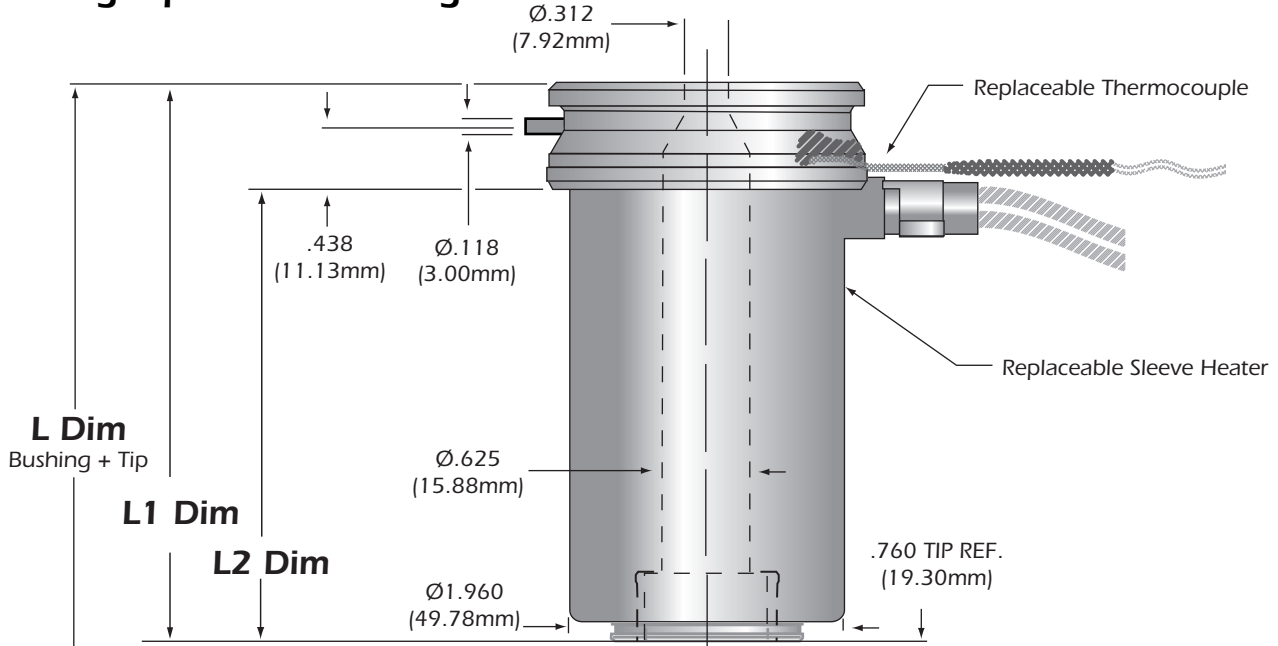

L Dim
Bushing + Tip

L1 Dim

L2 Dim

L Dim
Note*

L Dim
Bushing + Tip

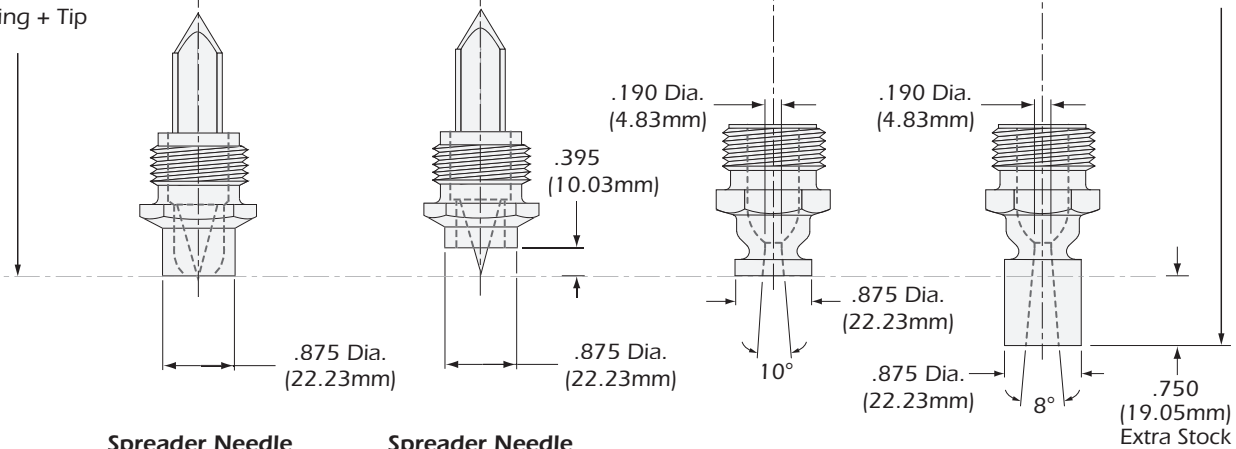

Spreader Needle Gate Insert

Spreader Needle Collar Gate

Sprue

Extra Stock Sprue

1.125
(28.58mm)

1.125
(28.58mm)

1.125
(28.58mm)

1.125
(28.58mm)

10

Dimensions are in inches. Millimeters are in parentheses.

*Note: Dimensions include extra stock.
**Note: For additional gate dimensions see page 12.

Accugate 625 Technical Specifications

MANIFOLD APPLICATIONS

Flat

625 Ordering Charts

Chart A

Part Number	L Dim. Gl, CG, Sprue		L Dim. Extra Stock Sprue		Body	Heater	L1 Dim.		L2 Dim.		T/C	Watts
HWA6203	3.750	(95.25)	4.500	(114.30)	AB62003	RH62000	2.990	(75.95)	2.240	(56.90)	TC00038	750
HWA6207	4.750	(120.65)	5.500	(139.70)	AB62007	RH62001	3.990	(101.35)	3.240	(82.30)	TC00039	750
HWA6211	5.750	(146.05)	6.500	(165.10)	AB62011	RH62002	4.990	(126.75)	4.240	(107.70)	TC00040	755
HWA6215	6.750	(171.45)	7.500	(190.50)	AB62015	RH62003	5.990	(152.15)	5.240	(133.10)	TC00041	930
HWA6219	7.750	(196.85)	8.500	(215.90)	AB62019	RH62004	6.990	(177.55)	6.240	(158.50)	TC00042	1100
HWA6223	8.750	(222.25)	9.500	(241.30)	AB62023	RH62005	7.990	(202.95)	7.240	(183.90)	TC00043	1275
HWA6227	9.750	(247.65)	10.500	(266.70)	AB62027	RH62006	8.990	(228.35)	8.240	(209.30)	TC00044	1450
HWA6231	10.750	(273.05)	11.500	(292.10)	AB62031	RH62007	9.990	(253.75)	9.240	(234.70)	TC00045	1625
HWA6235	11.750	(298.45)	12.500	(317.50)	AB62035	RH62008	10.990	(279.15)	10.240	(260.10)	TC00046	1795
HWA6239	12.750	(323.85)	13.500	(342.90)	AB62039	RH62009	11.990	(304.55)	11.240	(285.50)	TC00047	1970

Dimensions are in inches. Millimeters are in parentheses.

Tip Ordering Numbers

Chart B



Gate Style	Tip Alloy	Spreader Needle Assembly Part Numbers		
Gate Insert	Tip Alloy	0.100" Flat	0.125" Flat	0.150" Flat
	Standard	HT62030	HT62032	HT62034
	Wear Resistant	HT62031	HT62033	HT62035
Gate Style	Tip Alloy	Spreader Needle Assembly Part Numbers		
Collar Gate	Tip Alloy	0.100" Flat	0.125" Flat	0.150" Flat
	Standard	HT62040	HT62042	HT62044
	Wear Resistant	HT62041	HT62043	HT62045

Chart C

Gate Style	Tip Alloy	Part Number
	Standard	HT62010
	Wear Resistant	HT62011
Gate Style	Tip Alloy	Part Number
	Standard	HT62020
	Wear Resistant	HT62021

All specifications are subject to change without notification.

Accugate 625 Technical Specifications

MANIFOLD APPLICATIONS

625 Bore & Gate Dimensions

All specifications are subject to change without notification.

Tol. "a" Chart

in:	+ 0.001
	- 0
mm:	+ 0.02
	- 0

Tol. "b" Chart

in:	+ 0.0003m
	- 0.0003m
mm:	+ 0.0008m
	- 0.0008m

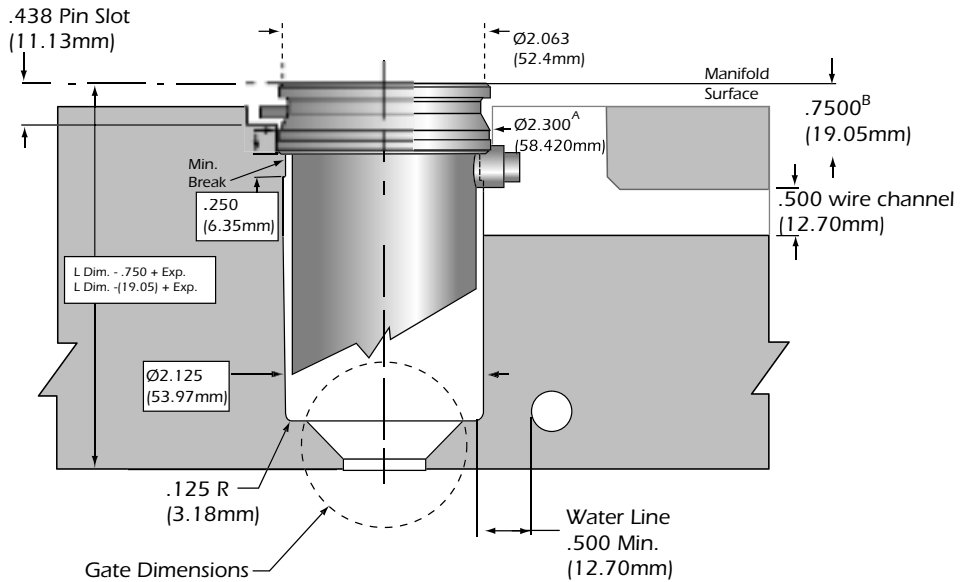

Thermal Expansion (Exp.) Formulas

$$\text{Exp. in} = (L \text{ in.} - .7500) \times 7.5 \times 10^{-6} \times (\text{Processing Temp.} - 70^\circ\text{F})$$

$$\text{Exp. mm} = (L \text{ mm.} - 19.05) \times 12.4 \times 10^{-6} \times (\text{Processing Temp.} - 21^\circ\text{C})$$

$$\text{Ref: } 10^{-6} = 0.000001$$

Dimensions are in inches. Millimeters are in parentheses.

Collar Gate

Non-Recessed Gate*

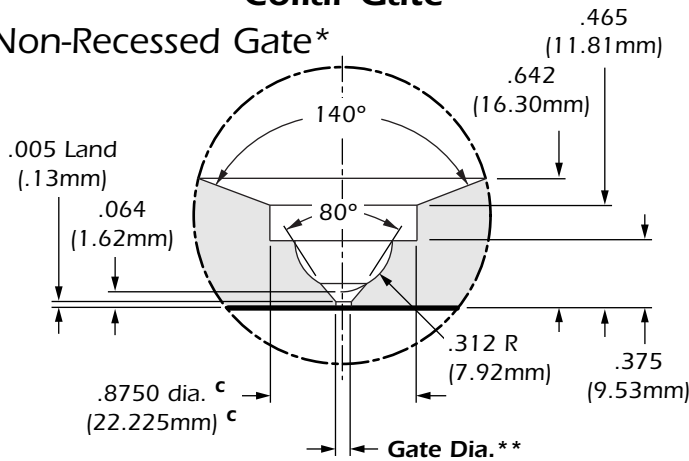

Gate Insert & Sprue Gate

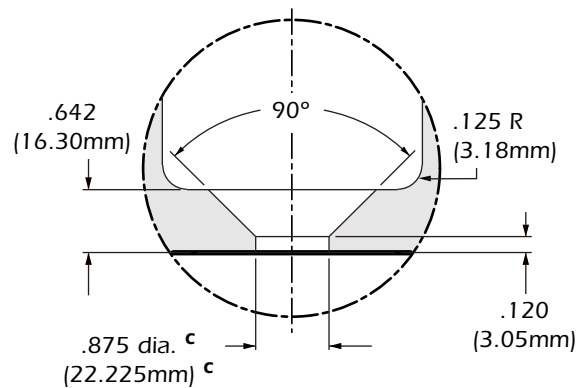

Recessed Gate*

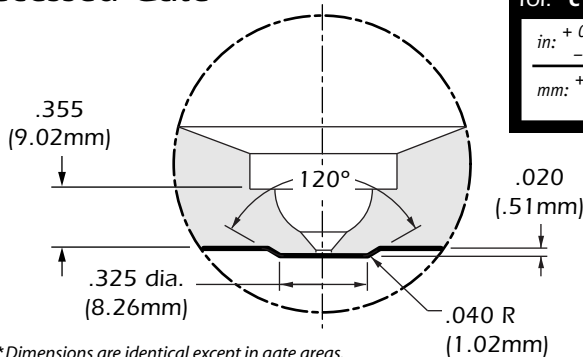

Tol. "c" Chart

in:	+ 0.0008
	- 0
mm:	+ 0.02
	- 0

Extra Stock Sprue Gate

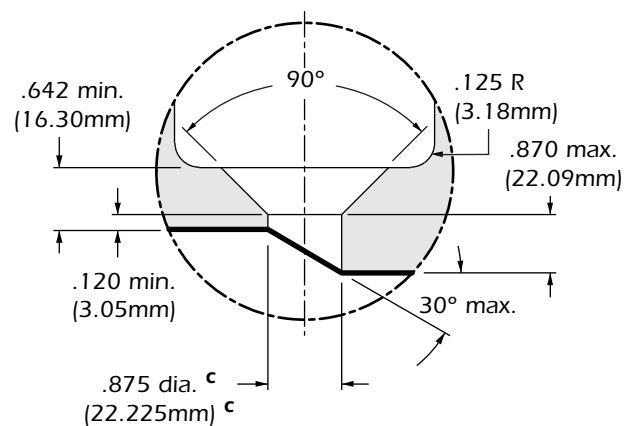

*Dimensions are identical except in gate areas.
**See Chart 2, page 13 for gate diameters.

Accugate 625 Technical Specifications

625 Engineering Charts

Chart 1

Tip Alloy Reference: STD = Standard, WR = Wear Resistant

All specifications are subject to change without notification.

Tip Style	Part No.	Alloy	Commodity Resin	Engineering Resin	Glass-Filled Resin
Sprue	HT62010	STD	●	●	
	HT62011	WR	●	●	●
Extra Stock Sprue	HT62020	STD	●	●	
	HT62021	WR	●	●	●
Gate Insert 0.100" Flat	HT62030	STD	●	●	
	HT62031	WR	●	●	●
Gate Insert 0.125" Flat	HT62032	STD	●	●	
	HT62033	WR	●	●	●
Gate Insert 0.150" Flat	HT62034	STD	●	●	
	HT62035	WR	●	●	●
Collar Gate 0.100" Flat	HT62040	STD	●	●	
	HT62041	WR	●	●	●
Collar Gate 0.125" Flat	HT62042	STD	●	●	
	HT62043	WR	●	●	●
Collar Gate 0.150" Flat	HT37044	STD	●	●	
	HT37045	WR	●	●	●

Reference: ● = Recommended

Chart 2

Spreader Needle tips	Resin Viscosity		
	High	Medium	Low
Gate Insert 0.100" Flat	.162" to .194"	.140" to .162"	.120" to .140"
Collar Gate 0.100" Flat	(4.10mm to 4.90mm)	(3.60mm to 4.10mm)	(3.00mm to 3.60mm)
Gate Insert 0.125" Flat	.187" to .219"	.165" to .187"	.145" to .165"
Collar Gate 0.125" Flat	(4.70mm to 5.60mm)	(4.20mm to 4.70mm)	(3.70mm to 4.20mm)
Gate Insert 0.150" Flat	.212" to .244"	.190" to .212"	.170" to .190"
Collar Gate 0.150" Flat	(5.40mm to 6.20mm)	(4.80mm to 5.40mm)	(4.30mm to 4.80mm)
Sprue tips	High	Medium	Low
All Sprue	.187" to .312"*	.187" to .312"*	.187" to .312"*
Part Numbers	(4.90mm to 7.90mm)	(4.70mm to 7.90mm)	(4.70mm to 7.90mm)

Reference: High Viscosity = Melt Flow (0.02 – 6); Medium Viscosity = Melt Flow (7 – 16); Low Viscosity = Melt Flow (16 – up). The values expressed in grams are for reference purposes only. Part dimensions, wall thickness, mold condition, and molding parameters must also be considered.

*Re-machine gate diameter, if necessary, for larger shot weights.

Dimensions are in inches. Millimeters are in parentheses.

Chart 3

Resin Viscosity	Sprue Tips & Collar Gate Tip - Flats						
	Extra Stock Sprue Tips	Gate Insert Tip - Flats			Collar Gate Tip - Flats		
		0.100"	0.125"	0.150"	0.100"	0.125"	0.150"
LOW	4000	600	900	1900	600	900	1900
MEDIUM	2000	500	800	1400	500	800	1400
HIGH	1000	400	700	1000	400	700	1000

Consult Heaterwerks when changing Max. shot weight.

MANIFOLD APPLICATIONS

Accugate Technical Specifications

Operating/Service Instructions

All specifications are subject to change without notification.

Operating & Servicing Instructions

The Accugate Nozzle bodies are identical in design, but differ in length, diameter and head style. All Accugate nozzles feature: unique sleeve heater design; Type "J" thermocouple; 36" teflon wrap - 600 Volt leamh; right angle lead exit; and 6" fiberglass sleeving.

Start-up/Operating Procedures

If the temperature controller does not utilize "soft start" technology, set the controller to 200°F (93.3°C) in automatic or 10% in manual. Allow bushing to "soak" for 15 minutes before increasing to processing temperature. This step will allow the unit to dissipate any moisture and prolong heater life.

Tip Removal/Installation

Removal

- 1) Secure the bushing firmly using a "V" block on the diameter or a vise against the flats machined on the head of the bushing
- 2) Use standard 9/16", 3/4", or 1-1/8" socket and remove tip by turning counter-clockwise.

Installation

- 1) Place bushing in "V" block and secure it firmly at the bushing head.
- 2) Apply anti-seize sparingly onto male thread of tip.
Note: Excess anti-seize may contaminate the resin being processed.
- 3) Use standard 9/16", 3/4", or 1-1/8" socket and install tip by turning clockwise.
- 4) **Torque to 30 ft./lbs. (41 Newton-Meters)**

Power Requirements

- 240 Volts AC – 15 amp fuse
- Grounding – Fast Heat bushings utilize the direct contact of the bushing, mold plates, and machine platens to establish a path for grounding.

WARNING

There must be a ground  present between the Mold "Hot Half" and the temperature control system or damage may occur to the nozzle, thermocouple and/or temperature control system.